

BU941

NPN SILICON TRANSISTOR

NPN POWER DARLINGTON HIGH VOLTAGE IGNITION COIL DRIVER

■ FEATURES

- * NPN Darlington
- * Integrated antiparallel collector-emitter diode

■ APPLICATIONS

- * High ruggedness electric ignitions

■ INTERNAL SCHEMATIC DIAGRAM

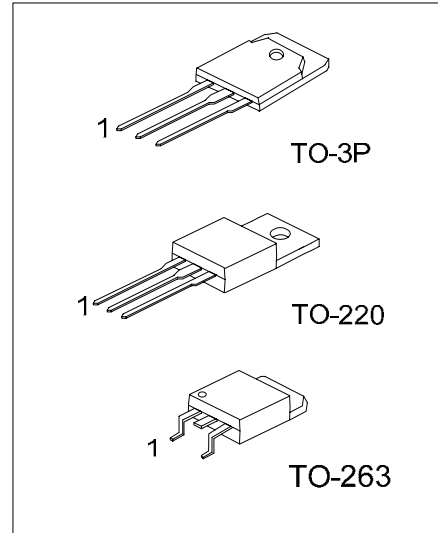
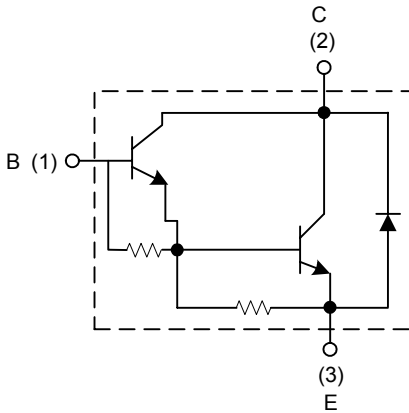

*Pb-free plating product number: BU941L

■ ORDERING INFORMATION

Ordering Number		Package	Pin Assignment			Packing
Normal	Lead Free Plating		1	2	3	
BU941-T3P-T	BU941L-T3P-T	TO-3P	B	C	E	Tube
BU941-TA3-T	BU941L-TA3-T	TO-220	B	C	E	Tube
BU941-TQ2-R	BU941L-TQ2-R	TO-263	B	C	E	Tape Reel
BU941-TQ2-T	BU941L-TQ2-T	TO-263	B	C	E	Tube

<p>BU941L-TA3-T</p> <ul style="list-style-type: none"> (1) Packing Type (2) Package Type (3) Lead Plating 	<ul style="list-style-type: none"> (1) R: Tape Reel, T: Tube (2) T3P: TO-3P, TA3: TO:220, TQ2: TO-263 (3) L: Lead Free Plating, Blank: Pb/Sn
--	---

■ ABSOLUTE MAXIMUM RATINGS

PARAMETER	SYMBOL	RATINGS	UNIT
Collector-Emitter Voltage	V_{CES}	500	V
Collector-Emitter Voltage	V_{CEO}	400	V
Emitter-Base Voltage	V_{EBO}	5	V
Collector Current	I_C	15	A
Collector Peak Current	I_{CM}	30	A
Base Current	I_B	1	A
Base Peak Current	I_{BM}	5	W
Total Power Dissipation ($T_c=25^\circ\text{C}$)	TO-3P	155	W
	TO-220	150	W
	TO-263	65	W
Junction Temperature	T_J	+175	$^\circ\text{C}$
Storage Temperature	T_{STG}	-65 ~ +175	$^\circ\text{C}$

Note Absolute maximum ratings are those values beyond which the device could be permanently damaged. Absolute maximum ratings are stress ratings only and functional device operation is not implied.

■ ELECTRICAL CHARACTERISTICS ($T_c=25^\circ\text{C}$, unless otherwise specified)

PARAMETER	SYMBOL	TEST CONDITIONS	MIN	TYP	MAX	UNIT
Collector-Emitter Sustaining Voltage	$V_{CEO(SUS)}^*$	$I_C=100\text{mA}$, $V_{clamp}=400\text{V}$, $L=10\text{mH}$ (see Fig. 1)	400			V
Collector Cut-Off Current	I_{CES}	$V_{CE}=500\text{V}$, $V_{BE}=0$ $V_{CE}=500\text{V}$, $V_{BE}=0$, $T_J=125^\circ\text{C}$			100 0.5	μA mA
Collector Cut-Off Current	I_{CEO}	$V_{CE}=450\text{V}$, $I_B=0$ $V_{CE}=450\text{V}$, $I_B=0$, $T_J=125^\circ\text{C}$			100 0.5	μA mA
Emitter Cut-off Current	I_{EBO}	$V_{EB}=5\text{V}$, $I_C=0$			20	mA
Collector-Emitter Saturation Voltage	$V_{CE(SAT)}^*$	$I_C=8\text{A}$, $I_B=100\text{mA}$ $I_C=10\text{A}$, $I_B=250\text{mA}$ $I_C=12\text{A}$, $I_B=300\text{mA}$			1.6 1.8 2	V
Base-Emitter Saturation Voltage	$V_{BE(SAT)}^*$	$I_C=8\text{A}$, $I_B=100\text{mA}$ $I_C=10\text{A}$, $I_B=250\text{mA}$ $I_C=12\text{A}$, $I_B=300\text{mA}$			2.2 2.5 2.7	V
DC Current Gain	h_{FE}^*	$V_{CE}=10\text{V}$, $I_C=5\text{A}$	300			
Diode Forward Voltage	V_F	$I_F=10\text{A}$			2.5	V
Functional Test		$V_{CC}=24\text{V}$, $V_{clamp}=400\text{V}$, $L=7\text{mH}$ (see Functional Test Circuit)	10			A
Fall Time	t_F	$V_{CC}=12\text{V}$, $V_{clamp}=300\text{V}$, $V_{BE}=0$, $R_{BE}=47\Omega$, $L=7\text{mH}$, $I_C=7\text{A}$, $I_B=70\text{mA}$ (see Fig.2)		15		μs
Storage Time	t_s			0.5		

*Pulsed: Pulse duration=300 μs , duty cycle 1.5%

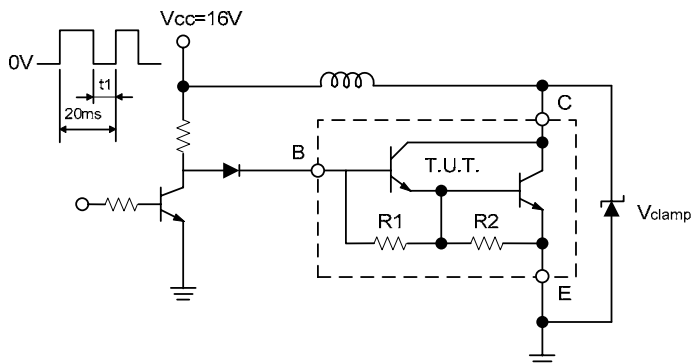

Fig. 1 Sustaining Voltage Test Circuit

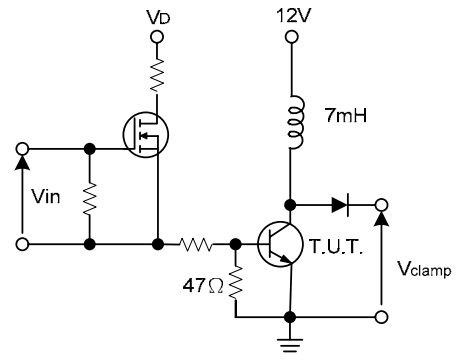
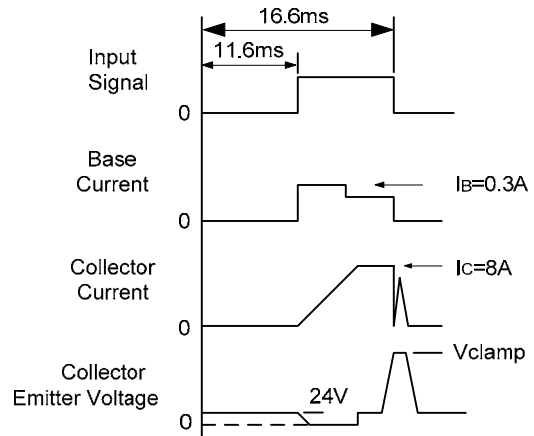
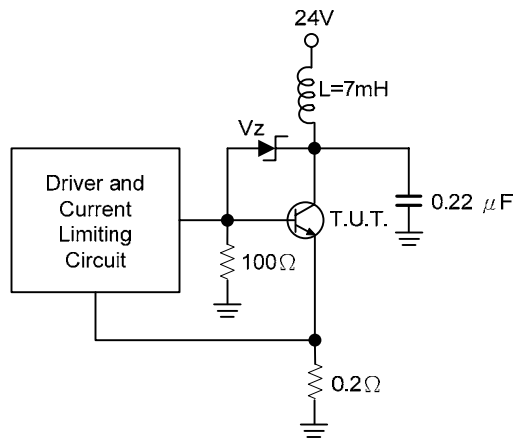
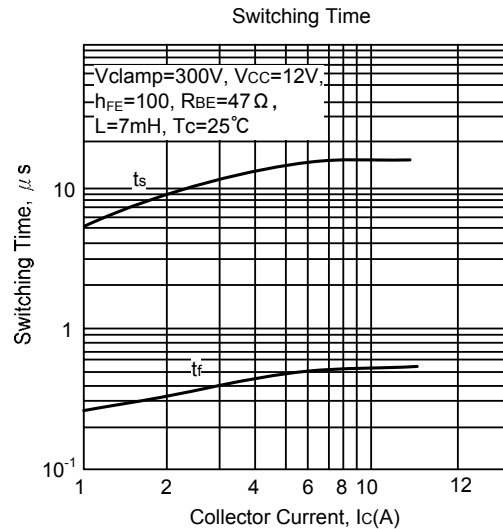
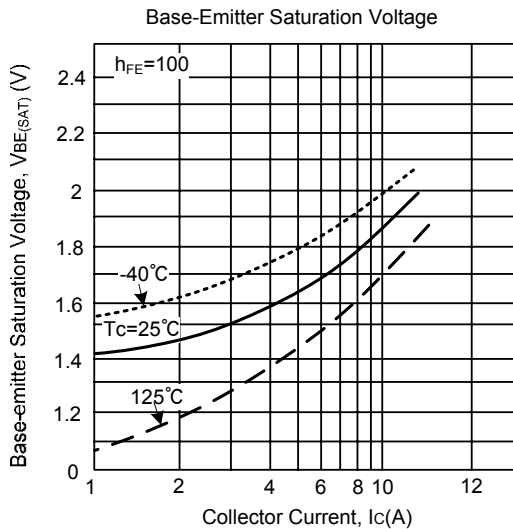
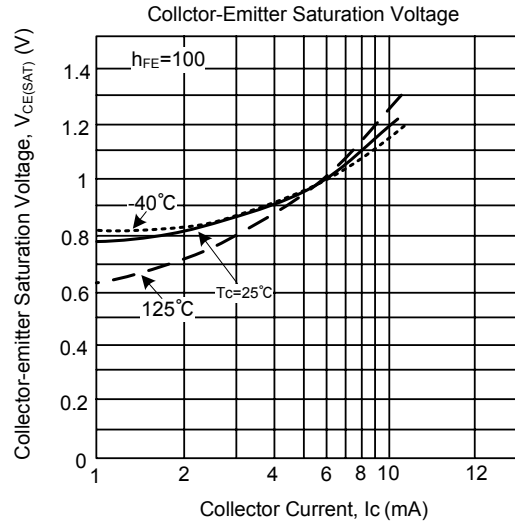
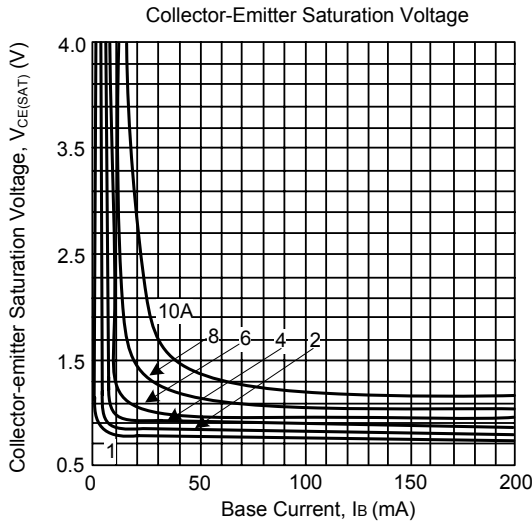
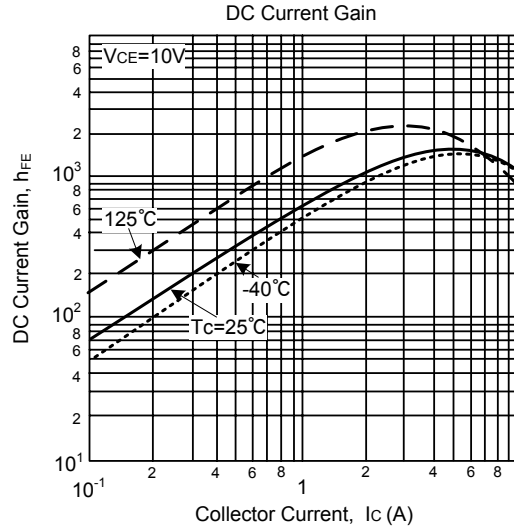
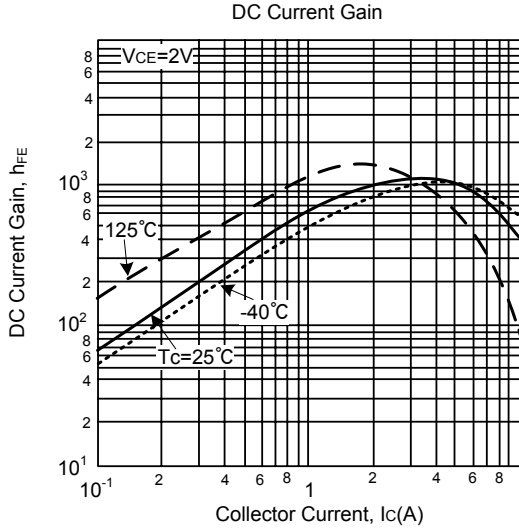

Fig. 2 Switching Time Test Circuit

■ FUNCTION TEST CIRCUIT



TYPICAL CHARACTERISTICS



■ TYPICAL CHARACTERISTICS(Cont.)

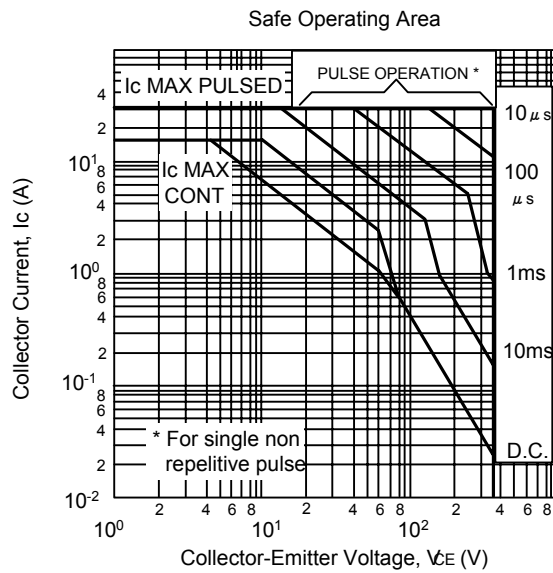

UTC assumes no responsibility for equipment failures that result from using products at values that exceed, even momentarily, rated values (such as maximum ratings, operating condition ranges, or other parameters) listed in products specifications of any and all UTC products described or contained herein. UTC products are not designed for use in life support appliances, devices or systems where malfunction of these products can be reasonably expected to result in personal injury. Reproduction in whole or in part is prohibited without the prior written consent of the copyright owner. The information presented in this document does not form part of any quotation or contract, is believed to be accurate and reliable and may be changed without notice.